

The ETM type A Series addresses the needs of standardized and routine testing, providing the user high quality at the most affordable price. The single column testing systems are suited for tension and/or compression applications where tests are less than 5 kN and lab space is limited. They are typically used for quality control and production testing.

Typical specimens: plastics, fine wire, fibers and threads, biomaterials, thin films, adhesives, foam, packaging, paper products, consumer products

New Features

- Robust linear motion guide increases lateral stiffness and ensure linear crosshead travel. This results in accurate crosshead alignment thus reducing variability in measurement data and producing better overall accuracy



- Imported servo motor with precise planet-gear speed reducer provides higher driving efficiency, low noise and free of maintenance. No need replace lubricates which has longer working life.



- Compact design saves lab space

High Quality at affordable price

- Pre-loaded ball screws and heavy duty bearings assure long life with zero backlash as well as linear low force and through zero performance. The result is accurate and repeatable measurements that truly represent the specimen characteristics rather than load frame deficiencies
- Fully-protected lead screw covers provide longer life and greater operator protection



- High-speed, low vibration, world-class, maintenance-free, AC servo motor and servo controller
- Photoelectrical encoder built in servo motor system is for position measurement of crosshead
- Built-in bidirectional load cell is assembled in the middle crosshead to prevent any collisions and simple to perform compression or tension tests
- Dual action over-travel limits on all frames provide the highest level of safety and meet all international standards
- Remote control keypad facilitates test operation
- Full one-year warranty on parts and labor
- Free software upgrading

Full complement of test accessories

Extensive range of accessories to meet test requirements in almost any application or industry: plastics, metals, biomedical, composites, elastomers, components, automotive, aerospace, textiles, and more.

- Tension grip
- Peel/tear fixture
- Compression fixture
- Flexure fixture
- Film COF test fixture
- Exchangeable load cells: 10N~2kN
- Long travel extensometer
- Clip-on extensometer

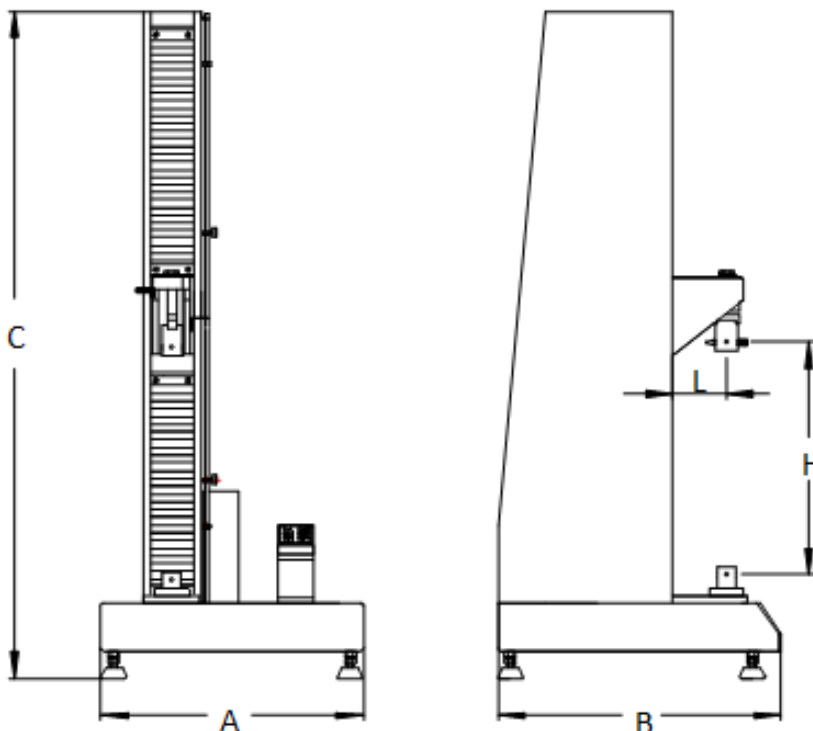

Machine dimension:

Frame type	Width x Depth x Height A x B x C (mm)	Crosshead travel H (mm)	Front opening space L (mm)	Adapter (mm)	Pin (mm)
Standard	490×530×1590	1000	100	Φ20	Φ10

Specifications:

Model	ETM501,ETM102,ETM202,ETM502, ETM103,ETM203,ETM503
Type	Type A, single column
Capacity	50N, 100N, 200N, 500N, 1kN, 2kN, 5kN
Calibration standard	ISO 7500, Class 1 / Class 0.5
Force range	0.2% ~ 100%FS / 0.4% ~ 100%FS
Force accuracy	±1% / 0.5% of reading
Force resolution	1/500000FS
Position accuracy	0.5% of reading
Position resolution	0.042μm
Crosshead speed	0.001 ~ 500mm/min
Crosshead speed accuracy	±1.0% / ±0.5% of set speed
Crosshead travel (without grip)	1100mm
Distance from loading center to dust cover	100mm
Dimension	530mm×490mm×1590mm
Power requirement	Single-phase, 220±10% VAC, 50/60Hz, 200W
Weight	90kg

Shipping information:

Package	Particleboard pallets and plywood case
Crated dimension (Width x Depth x Height)	700x700*1850mm
Crated weight	130kg



Shenzhen Wance Testing Machine Co., Ltd.

No.9, Shuiku Road, Tangwei,

Guangming District, Shenzhen 518107, China

Tel: +86-755-23057280 Fax: +86-755-23057995

Email: sales@wance.net.cn

www.wance.net